

EST4300-M Monocrystalline Silicon Pressure Transmitter

Product Introduction

EST4300M is type of Monocrystalline Silicon Smart Pressure Transmitter, it features 4-20mA+Hart to deliver accurate (0.075%/FS) outputs for data collection and control devices.

The pressure sensitive core element adopts high performance piezoresistive monocrystalline silicon chip, which is assembled in all-welded seal structure and filled with silicon oil in high vacuum.

By adopting the unique combination of several sensor systems in a single device, it allows simultaneous measurement of differential pressure and absolute pressure.

With ingress protection IP66, it commonly can be installed in industry of applications (liquid, gas, or steam) for monitoring filters and fans and level measurement of closed containers.



Applications

- Electricity
- Water Conservancy
- Metallurgy
- Environmental Protection
- Petrification
- Pharmacy
- Paper-making
- Furnace



Specification

Electrical Specification		
Output Signal	Two-wire 4~20mA +HART digital signal;	
	Saturation Current	Upper: 20.8 mA; Lower: 3.8 mA
	Alarm Current	Upper: 22.8 mA; Lower: 3.6 mA
Power Supply	24V dc (10.5-45) Vdc;	
	24V dc (10.5-26) Vdc; Intrinsic Safe	
Load Resistance	0~2119 Ω	In service
	250~600 Ω	In Hart Communication
Power Consumption	≤500mW@24VDC 20.8mA	
Power Line Spacing	15cm and above (Parallel Wiring Not Allowed)	
Bridge Resistance	6k ±0.5kΩ	
Response Time	10ms	
Technical Specification		
Measured Medium	Liquid; Gas	



Reference Accuracy	$\pm 0.1\%$ (≥ 40 kpa) $\pm 0.075\%$ / $\pm 0.1\%$ / $\pm 0.25\%$
	<i>Including Linearity Hysteresis+ Repeatability from zero; Square root output accuracy=1.5X of the linear</i>
Long-term Stability	$\leq 0.1\%$ /F.S/year
Calibration Temperature	$20^\circ\text{C} \pm 5^\circ\text{C}$
Temperature Drift @ Zero Point	$\leq 0.01\%$ F.S/ $^\circ\text{C}$
Sensitivity Temperature Drift	$\leq 0.01\%$ F.S/ $^\circ\text{C}$
Temperature Compensation	$-30^\circ\text{C} \sim 70^\circ\text{C}$
Transmit Distance	≤ 1000 m
Power Influence	$\leq 0.005\%$ F.S/V (Negligible)
Static Pressure Influence	$\leq 0.05\%$ F.S/10MPa
Overpressure Influence	$\leq 0.05\%$ FS/10MPa
Vibration Influence	0.1% of 200HZ/g @ any axis
Location Influence	400 pa at vertical or horizontal
Zero Drift	$-20\% \sim +20\%$ /F.S
Ingress Protection	IP66
Measuring Temperature	$-40^\circ\text{C} \sim 120^\circ\text{C}$ (Filling Fluid: Silico Oil) $-45^\circ\text{C} \sim 160^\circ\text{C}$ (Filling Fluid: Fluorocarbon Oil)
Environment Temperature	$-40^\circ\text{C} \sim 85^\circ\text{C}$; $-30^\circ\text{C} \sim 70^\circ\text{C}$ (LCD Display);
Environment Humidity	5-100% RH @ 40°C
Storage Temperature	$-40^\circ\text{C} \sim 110^\circ\text{C}$; $-30^\circ\text{C} \sim 70^\circ\text{C}$ (LCD Display);

Electro Magnetic Compatibility

1	Radiated Interference (Housing)	GB/T 6587-2012	30-1000MHZ	Q
2	Transmission Interference (DC terminal)	GB/T 6587-2012	0.15-30MHZ	Q
3	Immunity Interference (ESD: Electro-Static Discharge)	GB/T 17626.2-2006	4KV (contact)/8KV (in air)	B
4	Immunity Interference of Radiofrequency Electromagnetic	GB/T 17626.3-2006	10V/m (80MHZ-1GHZ)	A
5	Immunity Interference (PFMF)	GB/T 17626.8-2006	30A/m	A
6	Immunity Interference (EFT)	GB/T 17626.4-2006	2KV(5/50NS, 5KHZ)	B
7	Immunity Interference (Surge)	GB/T 17626.5-2006	2KV(ground wire)	B
8	Immunity Interference (CDN)	GB/T 17626.6/-2006	3V(150KHZ-80MHZ)	A

Note:

- Q: Perform qualified within the limitation of technical regulation
- A: Working in normal within the limitation of technical regulation
- B: During testing, functionality or performance may temporarily decrease or be lost, but it can recover on its own. The actual operating status, storage, and data remain unchanged.

Measuring Range

Range	Standard	Minimal	Lower	Upper	Static	Overpressure @High Voltage	Overpressure @Low Voltage
-3Kpa~0~3Kpa	3 Kpa	100 Pa	-3Kpa	3Kpa	16Mpa		
-6Kpa~0~6Kpa	6 Kpa	200 Pa	-6Kpa	6Kpa	16Mpa	25Mpa	16Mpa
-40Kpa~0~40Kpa	40 Kpa	400 Pa	-40Kpa	40Kpa	25Mpa	25Mpa	16Mpa
-250Kpa~0~250Kpa	250 Kpa	2.5 Kpa	-250Kpa	250Kpa	25Mpa	25Mpa	500Kpa
-1Mpa~0~1Mpa	1 Mpa	10 Kpa	-500Kpa	1Mpa	40Mpa	25Mpa	500Kpa
-3Mpa~0~3Mpa	3 Mpa	30 Kpa	-500Kpa	3Mpa	40Mpa	25Mpa	500Kpa

Note:

- Bilateral static pressure is only applicable to differential pressure series.
- The product should not be subjected to pressures exceeding the maximum overload pressure, otherwise the sensor will be damaged.

Structure Size

Outline Dimension

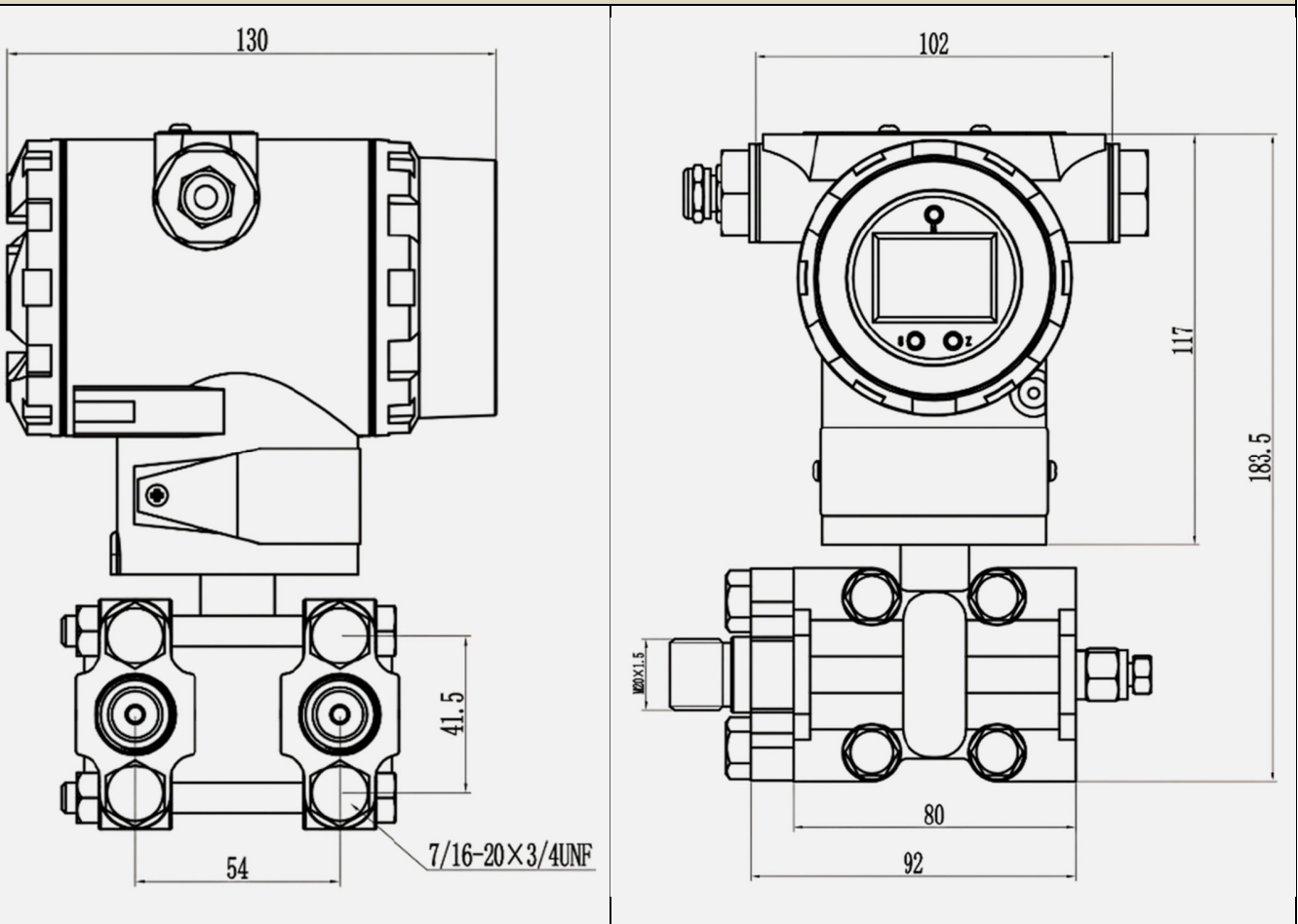

Drain/Vent Valve at Top	Drain/Vent Valve at Bottom	Drain/Vent Valve at Side
-------------------------	----------------------------	--------------------------

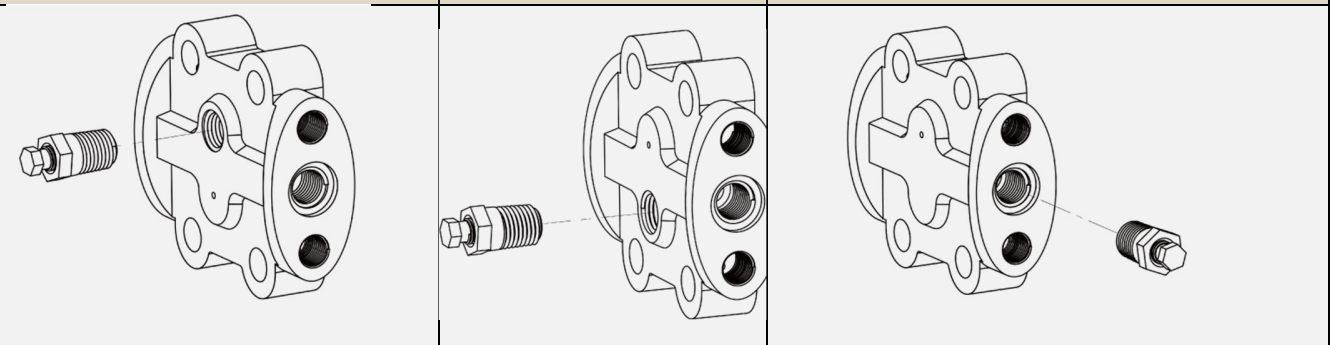

Note:

- For liquid process application, vertically mount the transmitter, and the side-mounted drain/vent valves at the top of the flange will allow gases to vent.
- For gas process application, vertically mount the transmitter, and the side-mounted drain/vent valves at the bottom of the flange will drain the liquid.

Exploded View & Field Installation

The Exploded View for reference

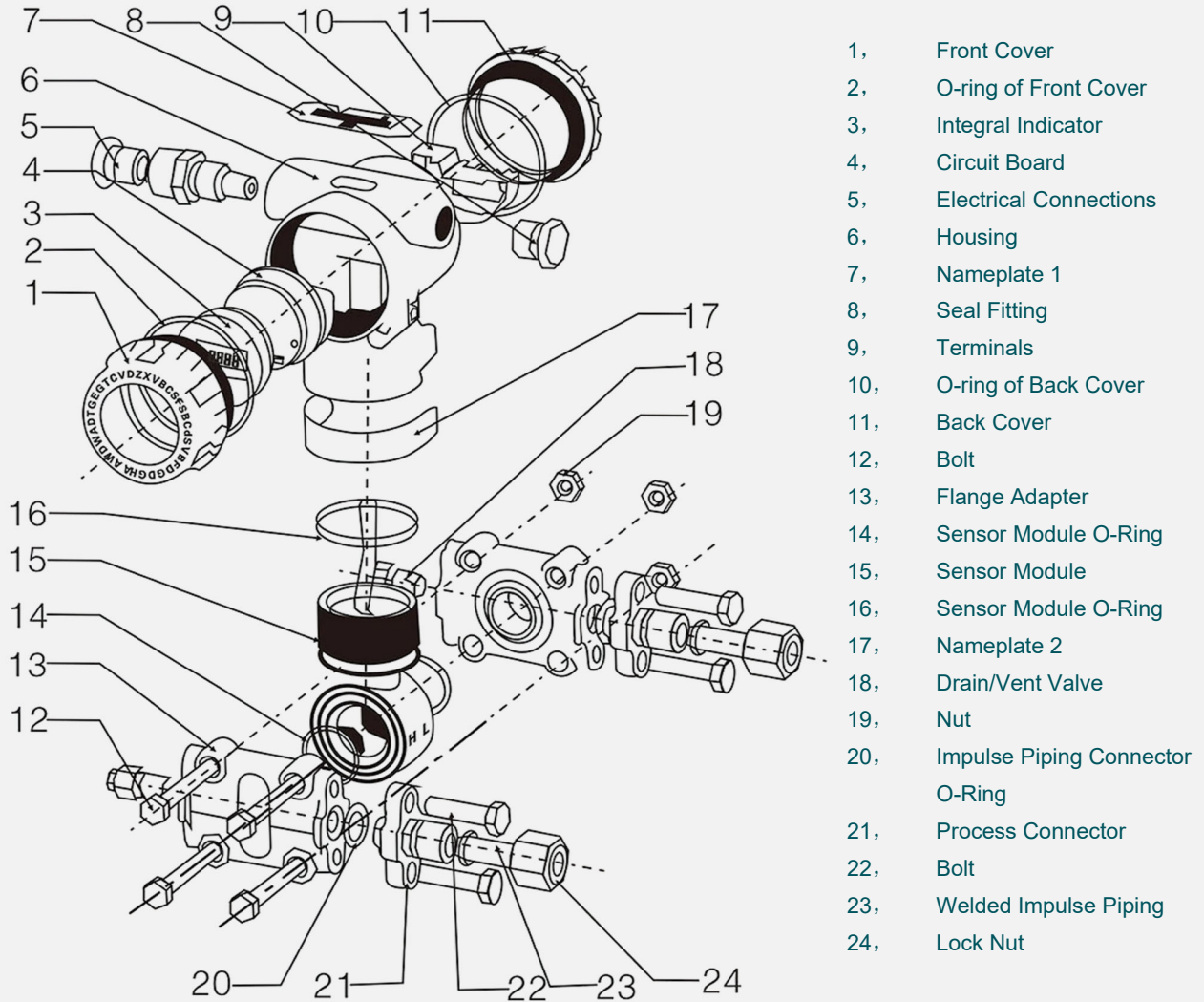

Field Installation: Pipe Mounting A

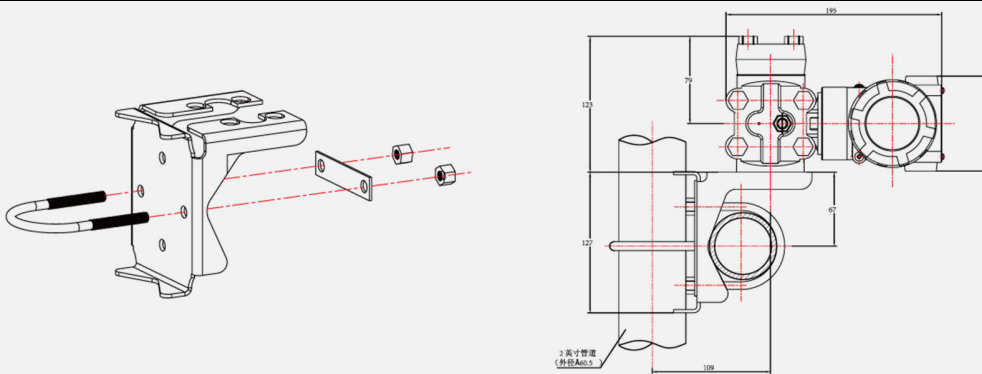

Field Installation: Plate Mounting

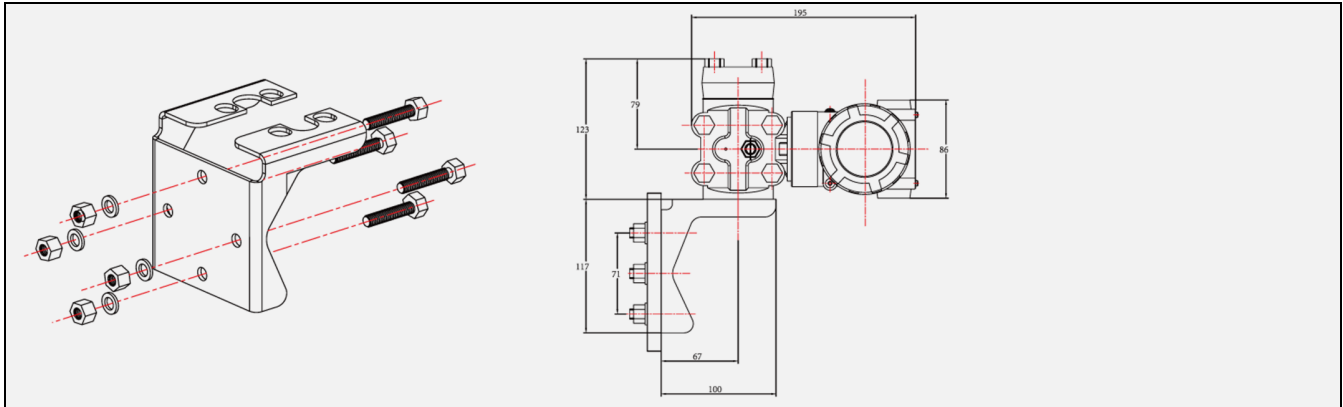

Field Installation: Pipe Mounting B

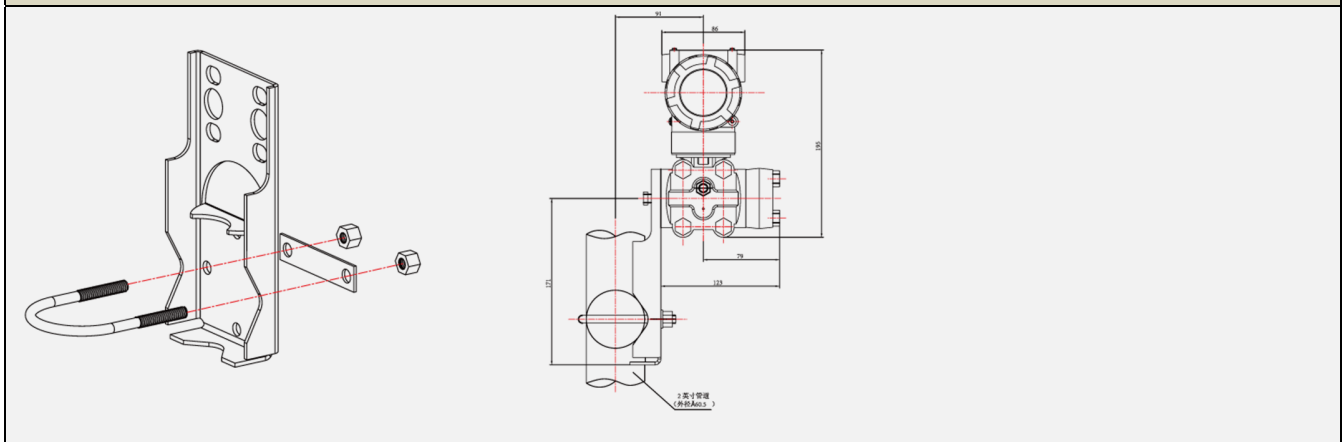

Impulse Piping Connections

<p>A: NPT Female Connection</p>	<p>B: NPT1/2 connector and back-welded impulse piping</p>	<p>C: T-shaped connector</p>
<ol style="list-style-type: none"> 1. Capsule Flange 2. O-Rings 3. A: NPT Female Connector 4. Flange Mounting M10*1.5 Thread 	<ol style="list-style-type: none"> 1. NPT1/2 and transition joint connecting with spherical cone 2. Nut M20*1.5 3. Ball joint (weldable with impulse piping at φ13) 	<ol style="list-style-type: none"> 1. Capsule Flange 2. O-Rings 3. Sphere-cone joint M20 *1.5 Male 4. Flange Mounting BoltM10*1.5 5. Nut 6. Ball jointweldable to impulsing pipe at φ13

Electrical Connection

Electrical Connection & Note				
	Connection			
	Output	Wires connection		
		①	②	③
LCD Display	Vcc	GND	\	
LCD +4-20mA	Vcc	Lout	\	
LCD +4-20mA+HART	Vcc	Lout	\	
Calibration		Note		
PV/Reset	Set the current analog output to correspond to zero pressure value (gauge pressure, differential pressure)			
Zero Adjust	Calibrate the output using the reference pressure @ 4mA			
Full Range Adjust	Calibrate the output using the reference pressure @ 20mA			
Restore factory settings	Restore factory backup data when adjustments result in errors.			

Display & Buttons

Display Screen Schematic.		
		Progress display area (Percentage form output) <hr/> Main Numerical Display Area (Displays 5 digits); <hr/> Character Display Area (Displays 8 English uppercase characters);
Buttons Calibration		

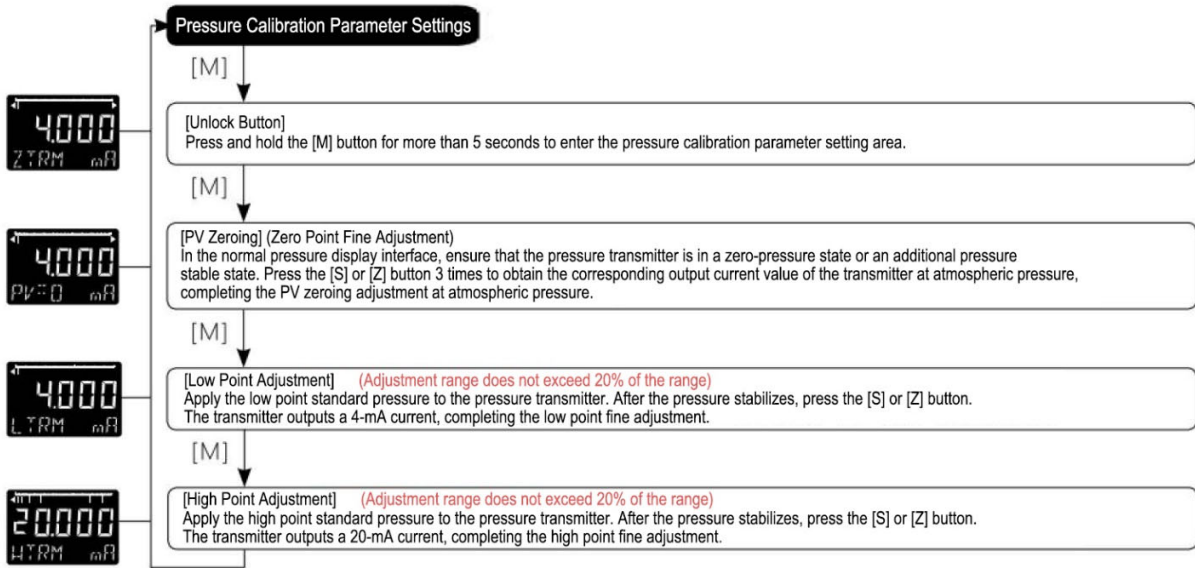

General Parameter Settings

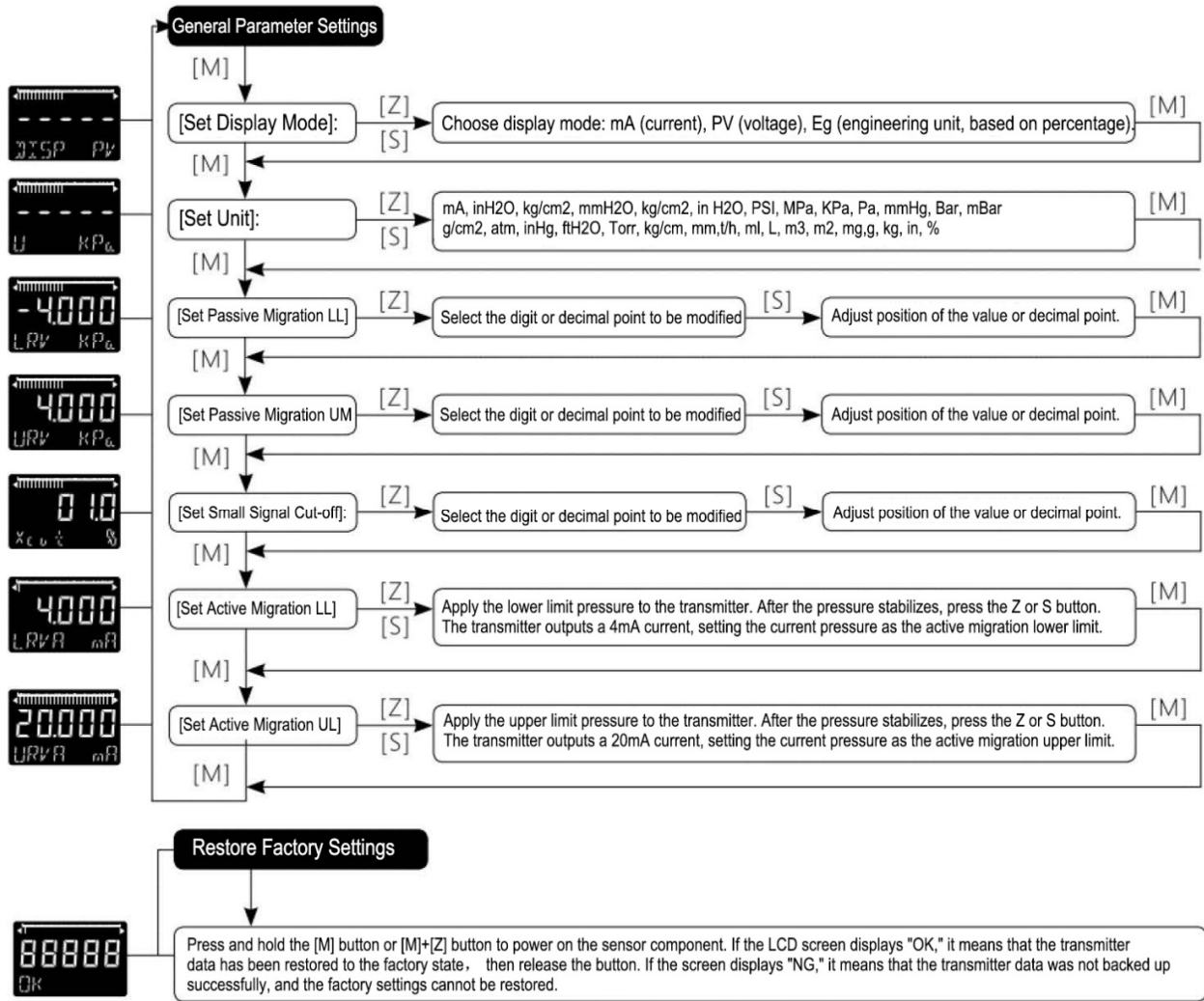

Troubleshooting

- If there is an abnormality in the measurement signal, determine whether it is due to process pressure anomalies, measurement system errors, or environmental influences in the installation location. Analyze the cause of the pressure transmitter abnormality and take appropriate measures.
- If there is no signal output from the product, or if the output signal does not correspond to changes in process pressure, it may be due to a pressure transmitter malfunction. Check if the power supply polarity, voltage, and load resistance meet the normal operating requirements. Also, check for pressure leaks, blockages in the impulse line, and whether the isolation valve is open.
- If the output signal has a large error or exceeds the normal range, check if the power supply voltage, power consumption, and load resistance meet the requirements for normal operation of the pressure transmitter. Verify the measurement range settings and calibration adjustments. Additionally, check for pressure leaks, blockages in the impulse line, whether the isolation valve is open, and if there are rapid temperature fluctuations in the installation location affecting the pressure transmitter.



Ordering Procedure

EST4300-M		Smart Differential Pressure Transmitter				
Code	Rang					
1	0~3Kpa					
2	0~6Kpa					
3	0~40Kpa					
4	0~250Kpa					
5	0~1Mpa					
6	0~3Mpa					
7	0~10Mpa					
8	0~20Mpa					
9	0~40Mpa					
0	0~60Mpa					
		Gauge Differential Absolute				
		Gauge Sealed Gauge				
Code	Output Type					
E	Linear Output 4-20mAdc					
S	Linear/Square root Output 4-20mAdc+HART signal					
Code	Construction Materials					
	Flange Adapter	Drain/Vent	Isolating	Code	Filled Fluid	
12	CS	CS	316 SST			
14	CS	CS	Monel			
22	316 SST	316 SST	316 SST			
23	316 SST	316 SST	Hastelloy Alloy C	SO	Silicone Oil	
24	316 SST	316 SST	Monel	FO	Fluorocarbon Oil	
25	316 SST	316 SST	Tantalum			
33	Hastelloy Alloy	Hastelloy Alloy C	Hastelloy Alloy C			
35	Hastelloy Alloy	Hastelloy Alloy C	Tantalum			
44	Monel	Monel	Monel			
Code	Impulse Piping Connection Style					
L1	1/4NPT-18 Female Thread (Standard Slotted Connector not					
L2	1/2NPT-14 Female Thread					
L3	M20×1.5 Male Thread					
Code	Options					
M1	0~100% Linear Meter					
M4	LCD Digital Meter					
B1	Pipe Mounting Bracket					
B2	Panel Mounting Bracket					
B3	Pipe Mounting Bracket					
D1	Side-mounted Drain/Vent Valve (TOP)					
D2	Side-mounted Drain/Vent Valve (TOP)					
X1	Oil Forbidden					
Da	Explosion-Proof ExdSIIBT5					
Fa	Intrinsically Safe ExialICT5					
EST4300M	3	S	24	L1	M4B3X1 0~3kPa	

Precautions

- Before use, please read this manual carefully to ensure the correct use of the product and avoid irreparable damage to the transmitter.
- Changes in the installation position parallel to the diaphragm surface will not affect zero drift. If the installation position changes more than 90° from the diaphragm surface, there will be a zero-position effect within the range of <math><0.4\text{kPa}</math>. This can be corrected by adjusting the zero calibration without affecting the measurement range.
- When cleaning the instrument, please use a cleaning agent that will not damage the instrument surface or sealing ring. When using a pressure cleaner, do not aim the nozzle directly at the electrical connection or vent hole (atmospheric communication position).
- The measuring medium must be a gas or liquid that will not corrode stainless steel, otherwise, it needs to be specially customized.
Do not press or clean the pressure hole with your hand or other hard and sharp objects to avoid damaging the chip.
- This product is a measuring product, so it should be handled with care and not disassembled. Such damage is not covered by the warranty.
- The entry of viscous liquids will affect the measurement accuracy and should be avoided as much as possible.

LIMITED WARRANTY

Seller warrants that the product hereby purchased is, upon delivery, free from defects in material and workmanship and that any such product which is found to be defective in such workmanship or material will be repaired or replaced by Seller (Ex-works, Factory, Xi'an China. INCOTERMS); provided, however, that this warranty applies only to equipment found to be so defective within a period of 18 months from the date of manufacture by the Seller. Seller shall not be obligated under this warranty for alleged defects which examination discloses are due to tampering, misuse, neglect, improper storage, and in any case where products are disassembled by anyone other than authorized Seller's representatives. EXCEPT FOR THE LIMITED WARRANTY OF REPAIR AND REPLACEMENT STATED ABOVE, SELLER DISCLAIMS ALL WARRANTIES WHATSOEVER WITH RESPECT TO THE PRODUCT, INCLUDING ALL IMPLIED WARRANTIES OF MERCHANTABILITY OR FITNESS FOR ANY PARTICULAR PURPOSE. specifications subject to change without notice.



EASTSENSOR TECHNOLOGY LTD
0701 No.5 Plaza N.F.C Chang'an South
Rd. Yanta Dis. Xi'an P.R.China
Tel: +86-29-85576843
Mob: +86-13629297491
E-mail: info@eastsensor.com
Website: www.eastsensor.com